

HELU Schweißtechnik Handzangen

Integrierter Transformator

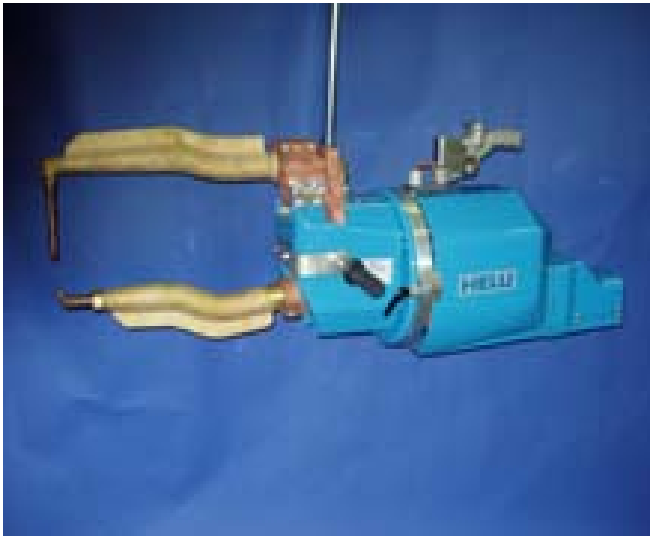

Kabel-Handzangen

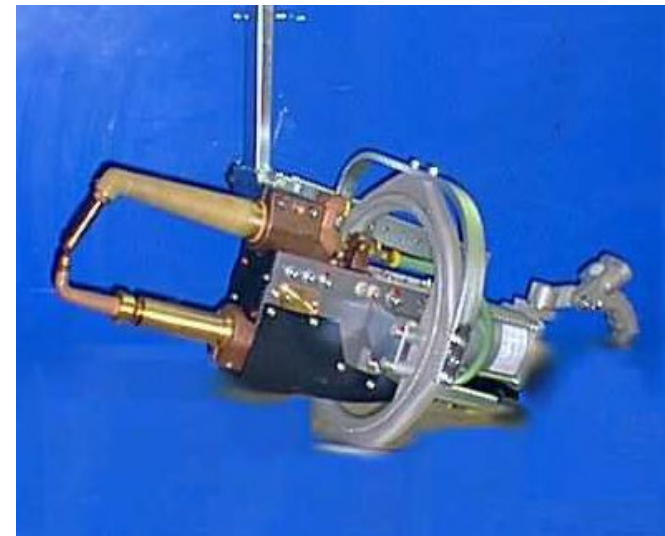

- Trafo-Handschiweißzangen
 - Integrierter Transformator AC/MFDC
 - Geringe elektromagnetische Strahlung für den Werker
 - Kleinere Transformator Größen
 - Höherer Wirkungsgrad
 - Weniger Verluste
 - Größeres Gewicht

- Kabel-Handschiweißzangen
 - Transformator extern
 - Höhere Verluste
 - Höhere elektromagnetische Strahlung für den Werker
 - Geringeres Gewicht
 - Kompakt und einfach zu bedienen

Elektrodenkräfte bei 5 bar

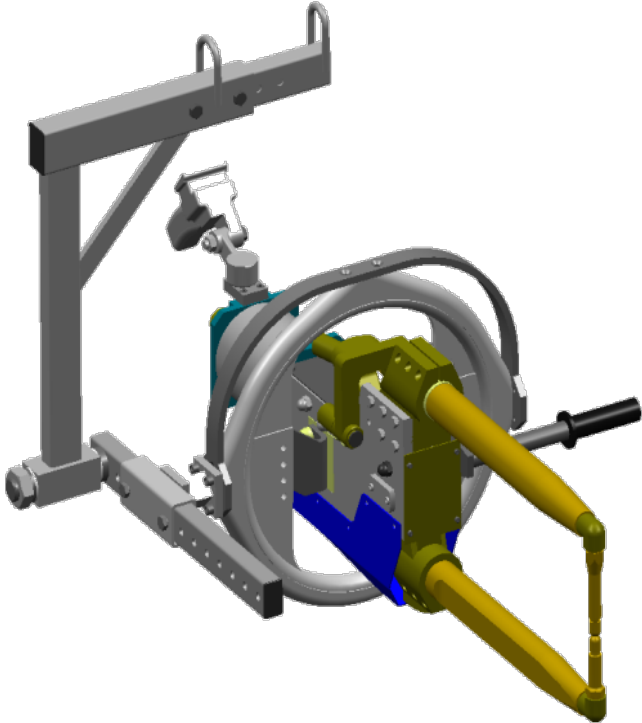
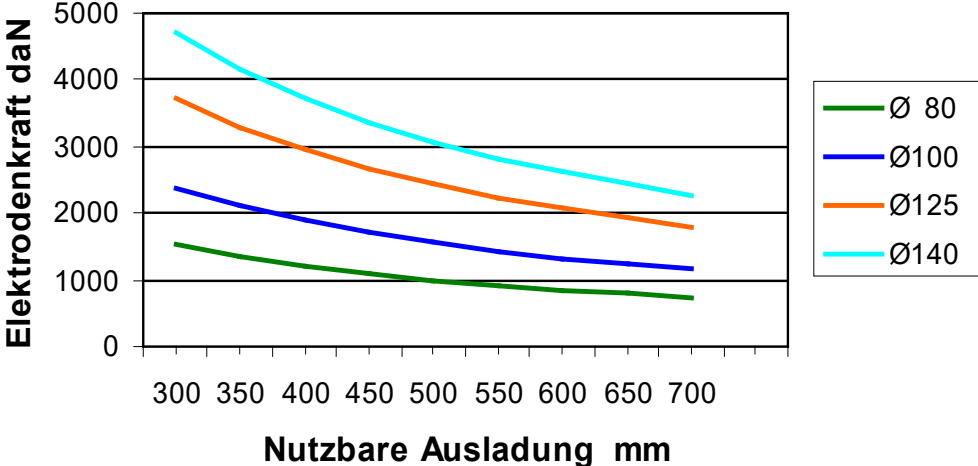

Elektrodenkräfte

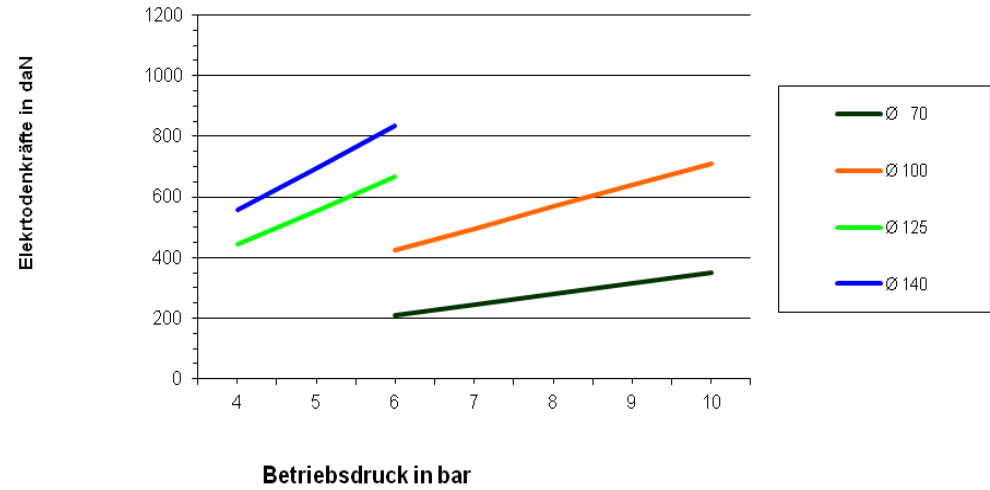

- Ergonomisch
- Kompakt
- Wartungsfreundlich
- Volkswagen hat die HELU Konstruktion für den eigenen Haus-Standard übernommen

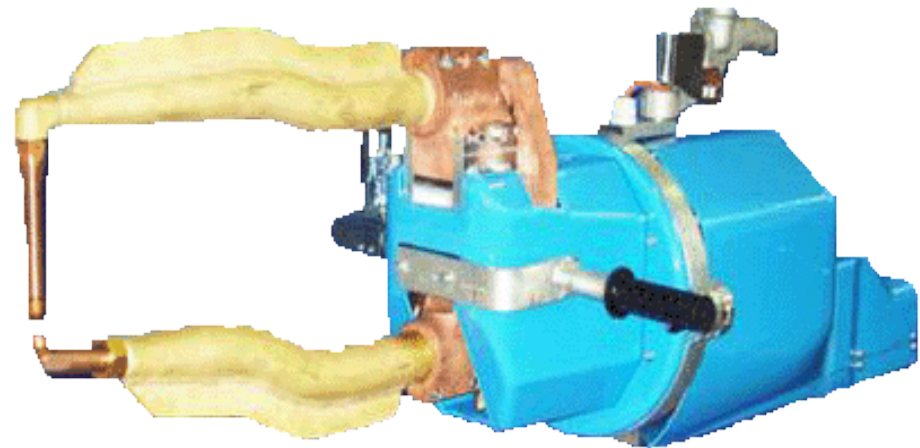

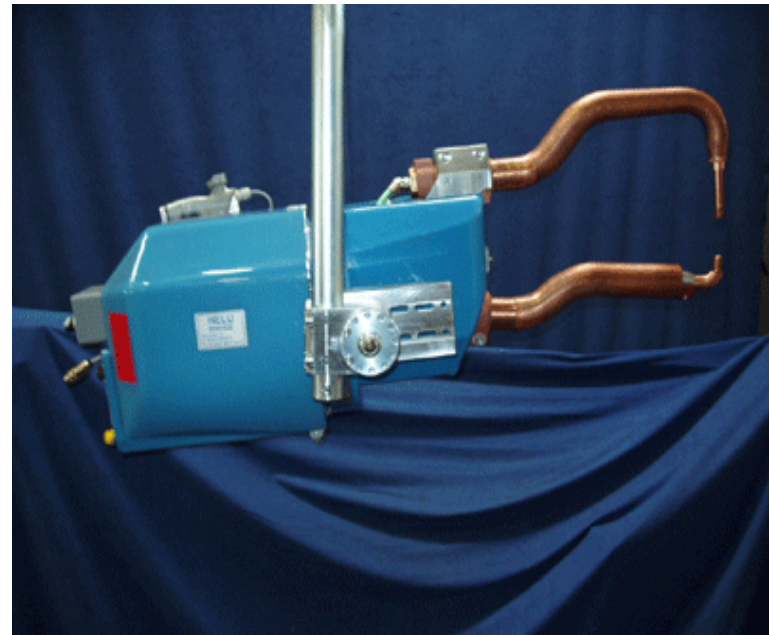

max. Electrode force at 5 bar

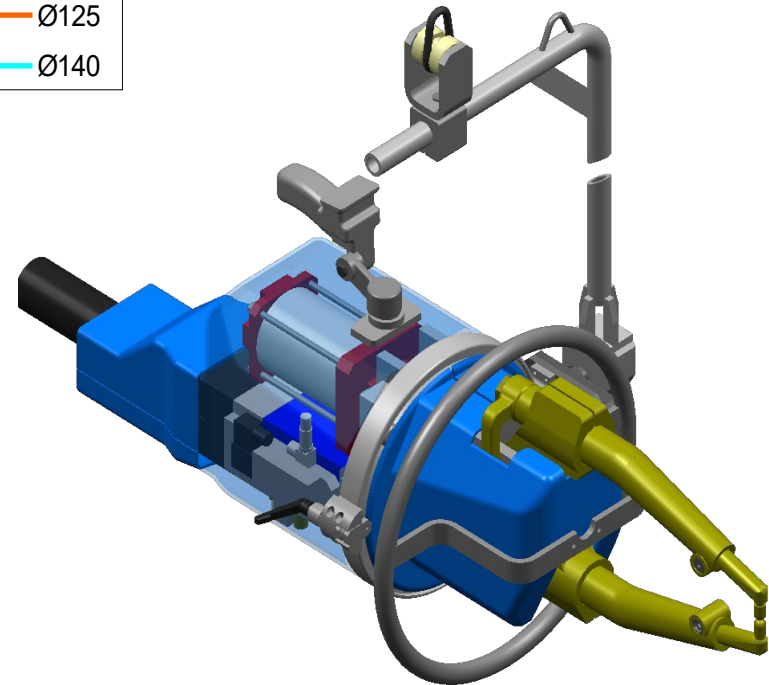
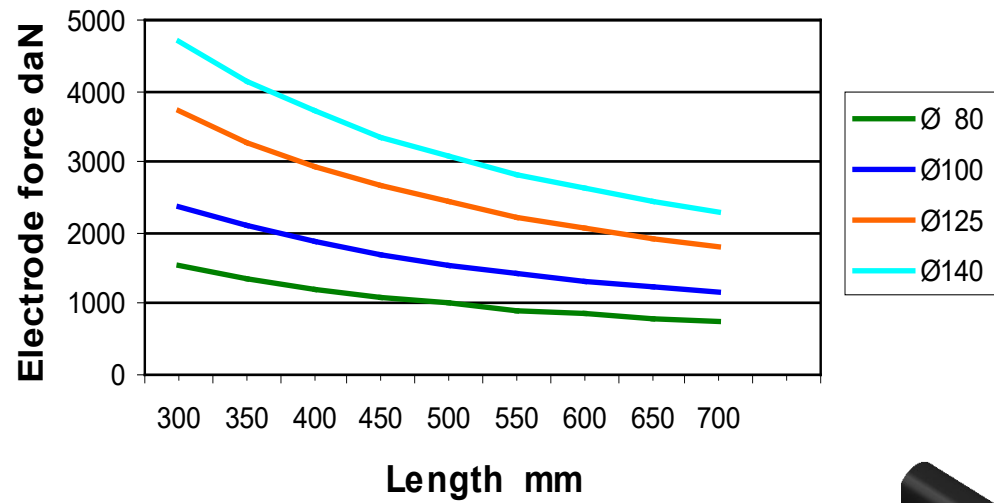





Electrode force

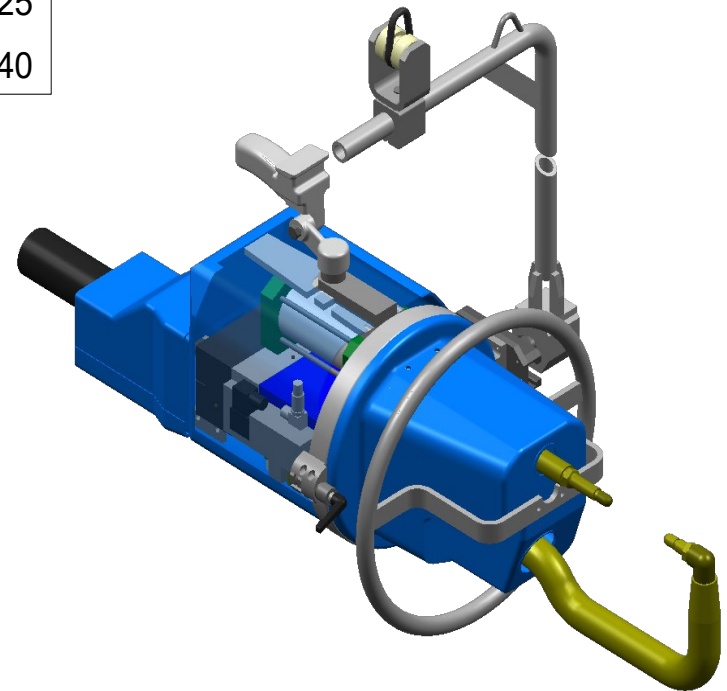
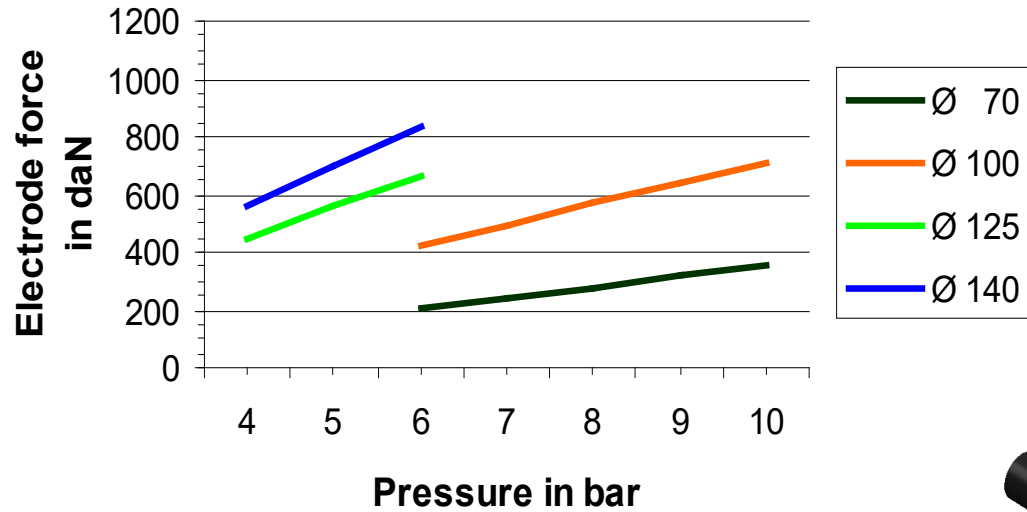

- Stabile Konstruktion
- Hohe Schweißkräfte
- Nutzbare Ausladung bis 1500 mm

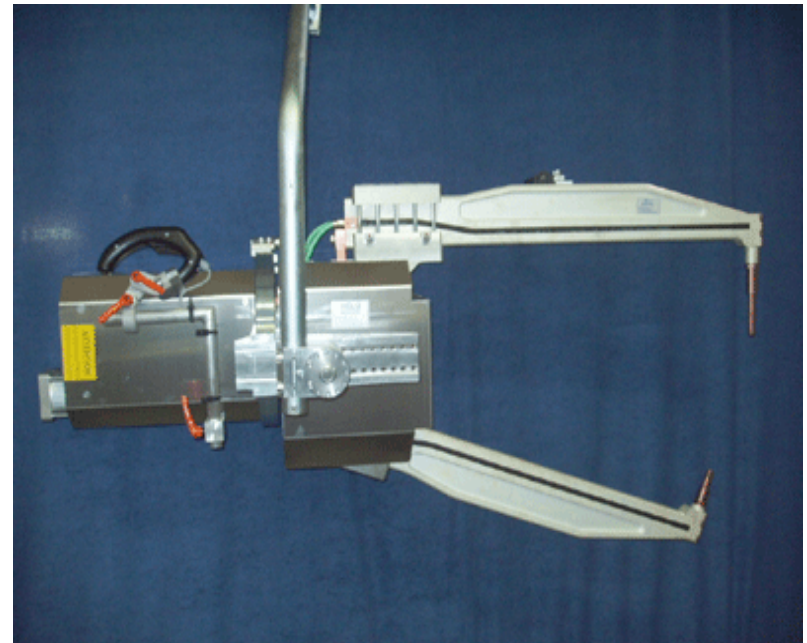
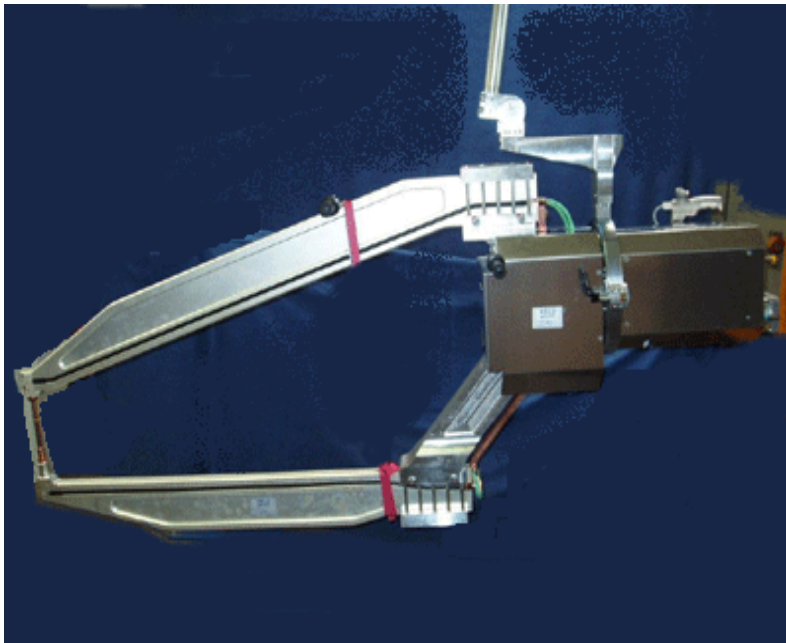

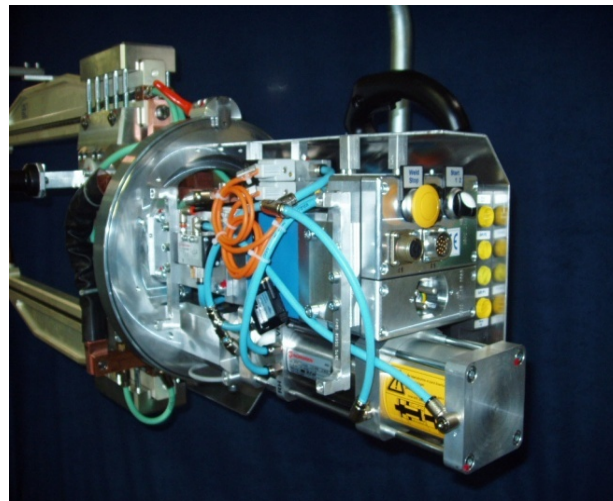
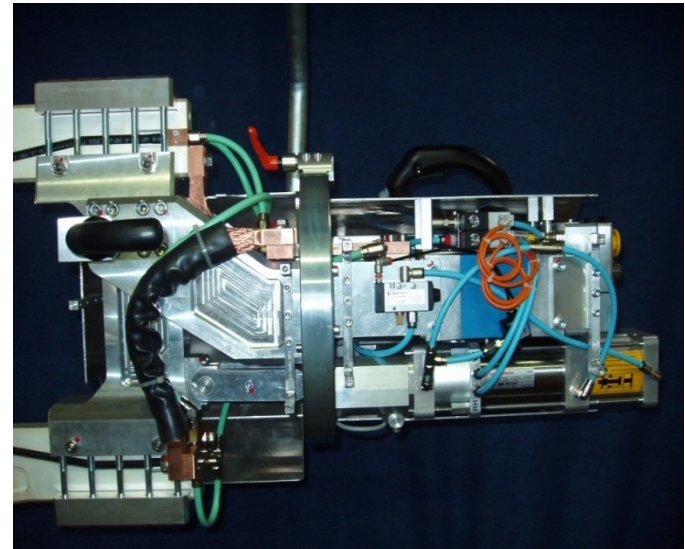
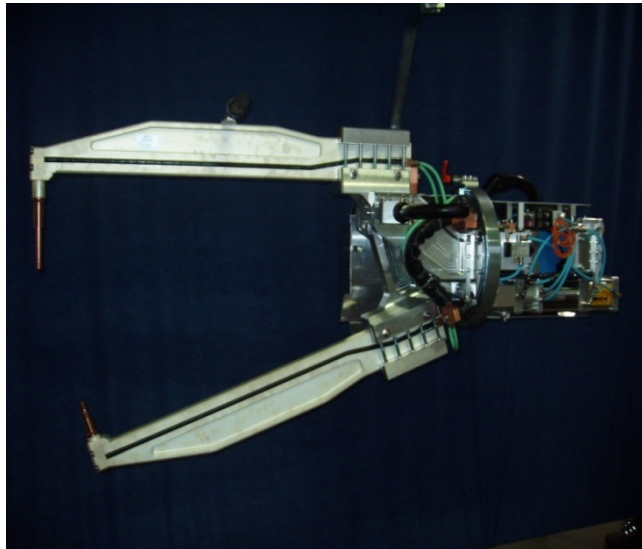

max.Elektrodenkräfte bei 4bar

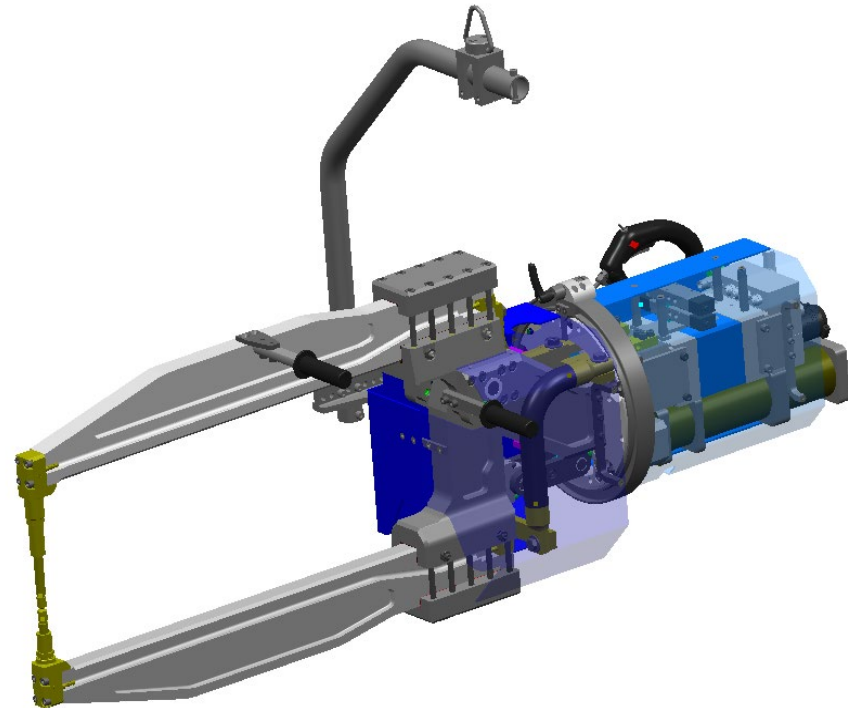
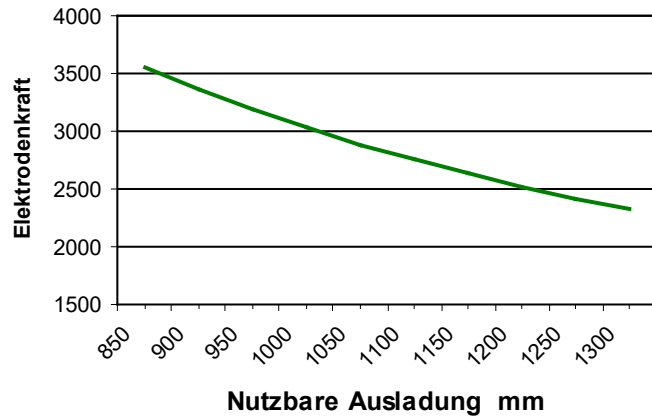

HELU GmbH
Seehofstraße 56-58
64653 Lorsch

Telefon +49 (0) 6251-592-280

Telefax +49 (0) 6251-592-288

E-Mail info@helu.de

Internet www.helu.de

YouTube 